

# LED UFO High Bay – Gen 2

LUHB2 Series – Wattage Tunable

Project:	
Catalog#:	
Approved by:	

## Features

- ADC12 Aluminum die-cast heatsink
- Ultra-durable Powder Coat Paint
- Standard Color Black
- Polycarbonate lens, High light transmittance, Anti-UV, Fire Resistant
- Comes standard with a high bay hanging hook
- Fixtures include approx. 11 inch long dimming leads and approx. 3 ft long input power cable stripped at ends
- Color Temperature: 5000K standard (cool white), other colors available
- Color Rendering Index (CRI) > 80
- Long LED life; L<sub>70</sub> > 150,000 hours
- Rated for Ambient Temperatures between -40°C/-40°F to 50°C/122°F
- Input Voltage: 100 – 277V; 50/60 Hz
- Wattage Tunable: 150/100/80/50W
- Power Factor (PF) > 0.9
- Total Harmonic Distribution (THD) < 20%
- Dimmable: 0-10Vdc
- Distribution: 90° beam angle standard
- UL/cUL Listed
- IP65
- Warranty: 5 years

## Applications

- Warehouse
- Auditorium
- Retail Space
- Manufacturing Facility



## Ordering Information

Model Name	Color Characteristics	Field Selectable		Input Voltage	Surge Protection	Distribution	Dimensions (inches)	Comparable to HID
		Input Power (W)	Delivered Lumens					
LUHB250BMV	5000K > 80 CRI	150*	22,200*	100-277V 50/60Hz	4kV	90° beam angle	Diameter - 12.6" Height - 7.8"	400W
		100	14,800					
		80	11,850					
		50	7,400					

\*Default settings at factory.

## Wattage Tuning

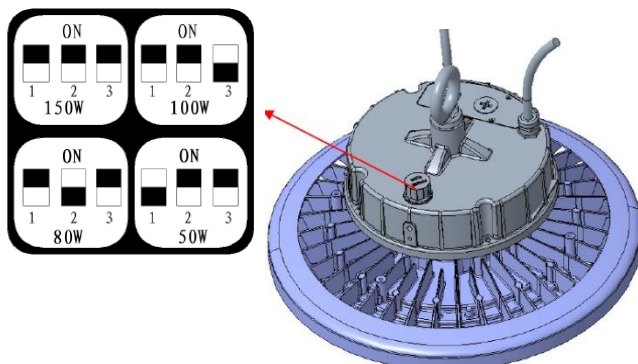

## Photometrics

